

SCHMATIC DIAGRAM - HS-2339

MOTOROLA Chassis HS-2339 Service Information

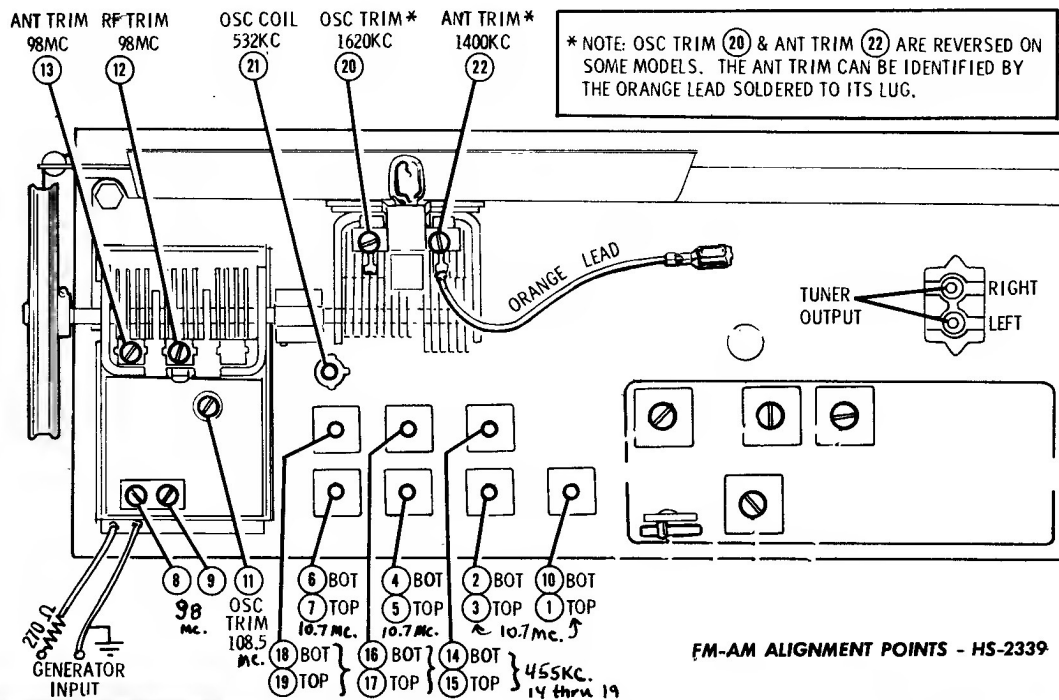

FM-AM ALIGNMENT POINTS - HS-2339

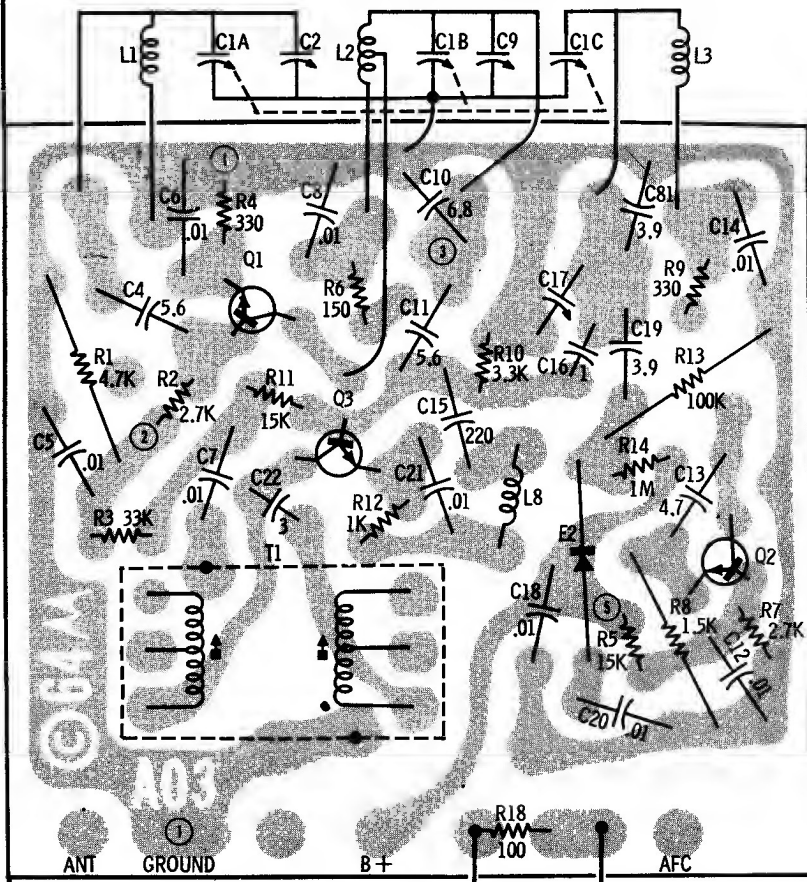

TOP VIEW

FM RF PLATED BOARD (PART OF CHASSIS HS-2339)

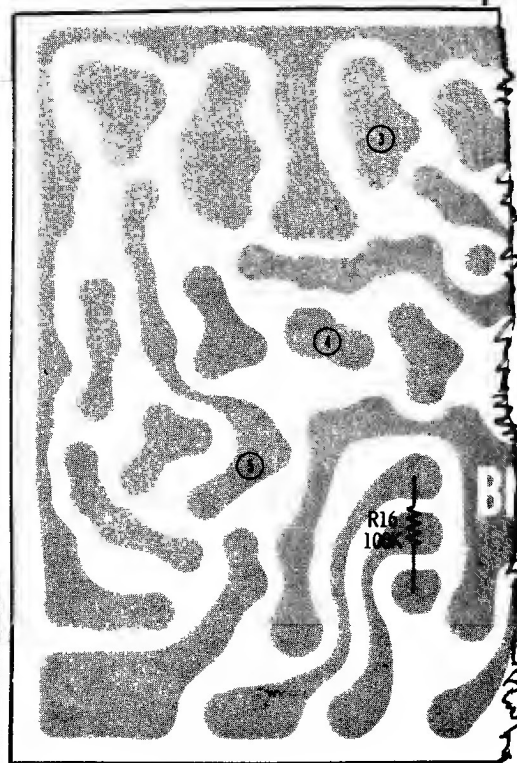

BOTTOM VIEW

FM RF PLATED BOARD (PART OF CHASSIS HS-2339)

MOTOROLA MODELS PP301B, 302B; SP310B; PK400B, 401B; SK450B
 THRU 453B, 500B THRU 509B; 23LK412B THRU 416B
 CHASSIS HS-2334, HS-2336, HS-2339, HS-2349

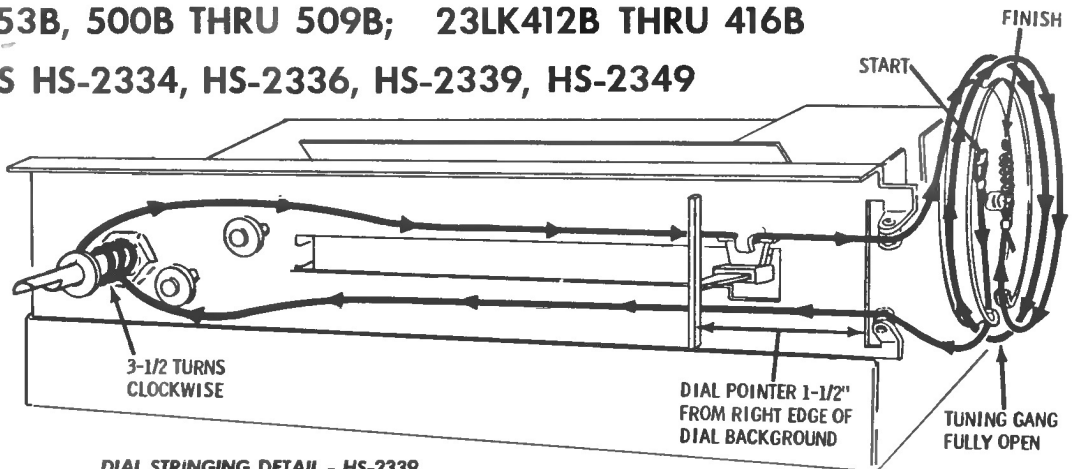

DIAL STRINGING DETAIL - HS-2339

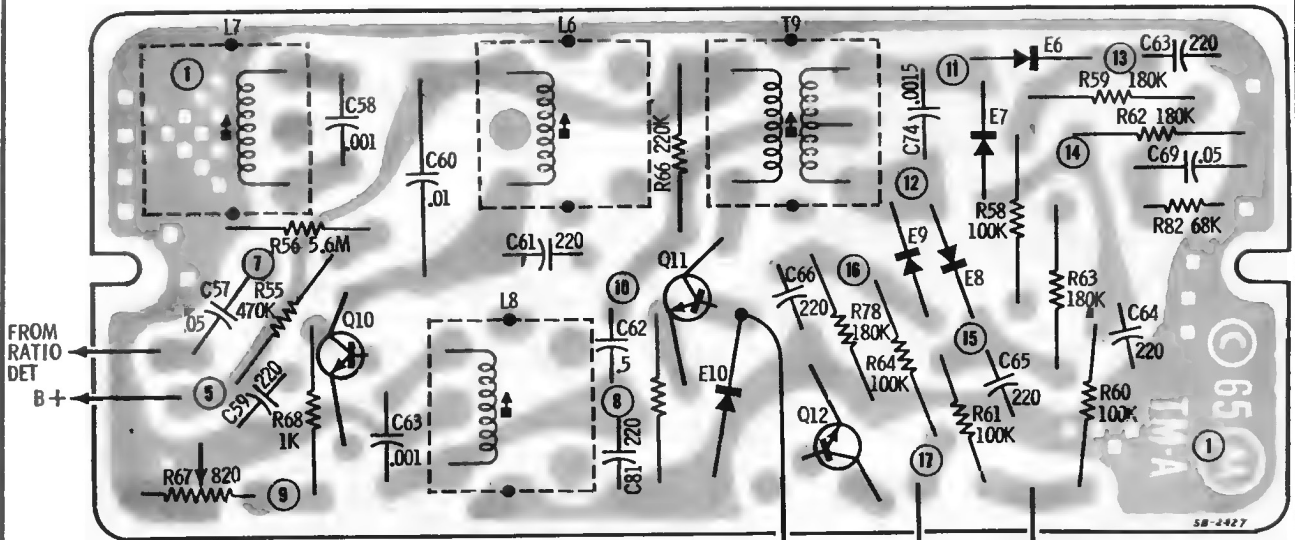

TOP VIEW

MULTIPLEX PLATED BOARD (PART OF CHASSIS HS-2339)

TO PILOT
SQUELCH

RIGHT
AUDIO

LEFT
AUDIO

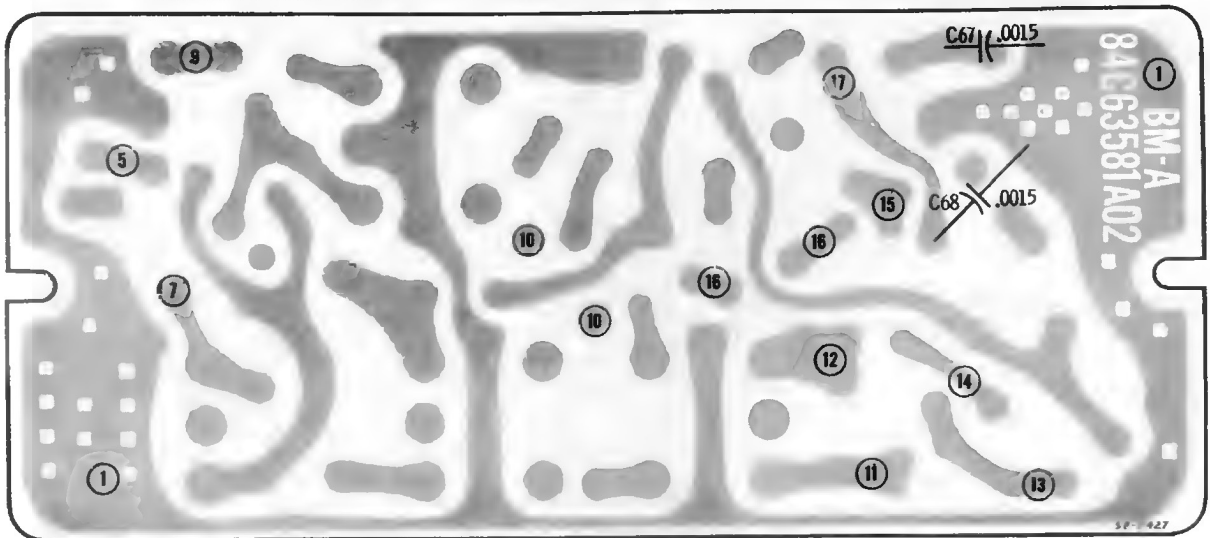

BOTTOM VIEW

MULTIPLEX PLATED BOARD (PART OF CHASSIS HS-2339)

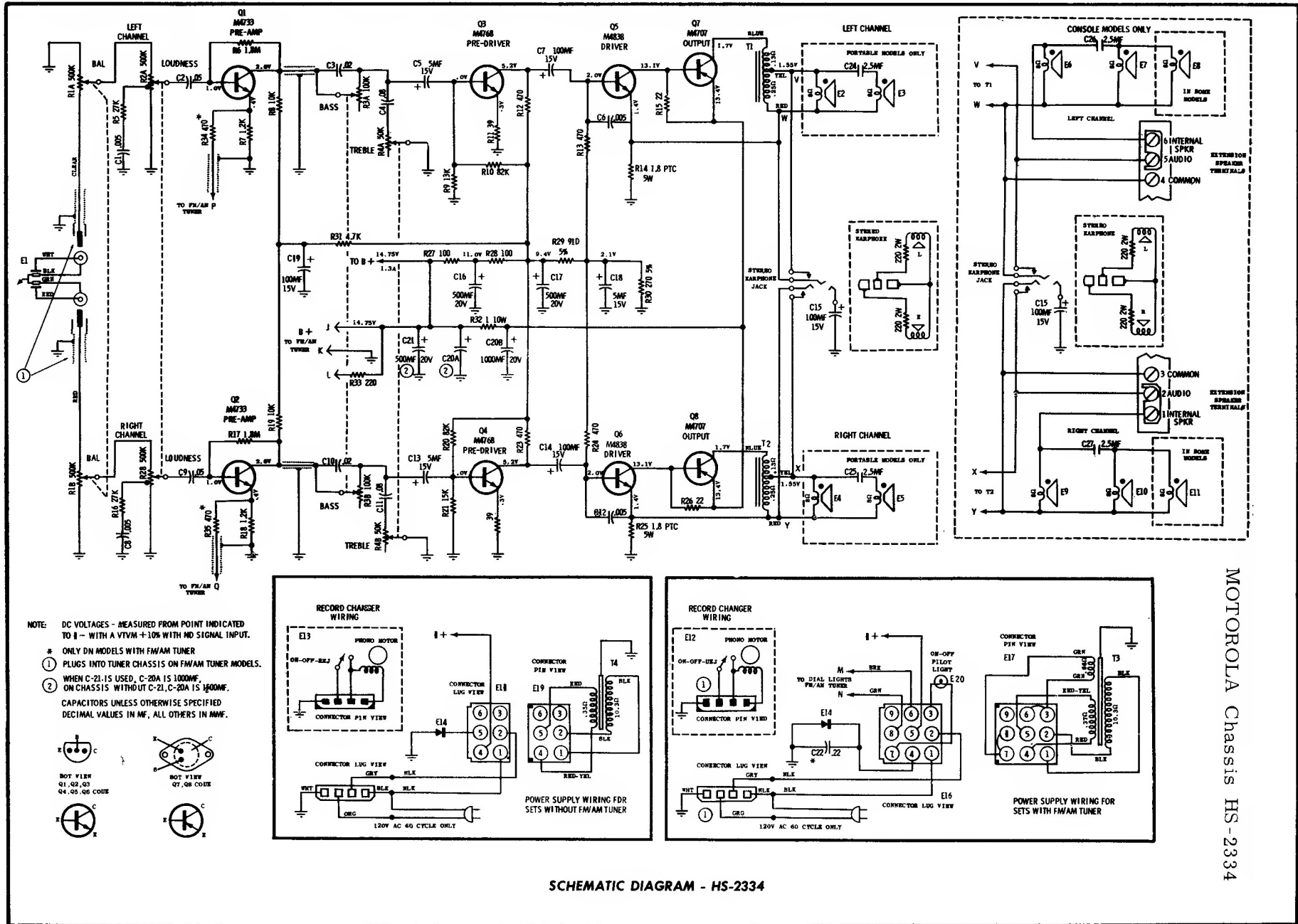

NOTE: DC VOLTAGES - MEASURED FROM POINT INDICATED TO B - WITH A VTVM +10% WITH NO SIGNAL INPUT.

ONLY ON MODELS WITH FM/AM TUNER

① PLUGS INTO TUNER CHASSIS ON FM/AM TUNER MODELS.

② WHEN C-21 IS USED, C-20A IS 1000NF. ON CHASSIS WITHOUT C-21, C-20A IS 1000NF. CAPACITORS UNLESS OTHERWISE SPECIFIED DECIMAL VALUES IN NF, ALL OTHERS IN MMF.

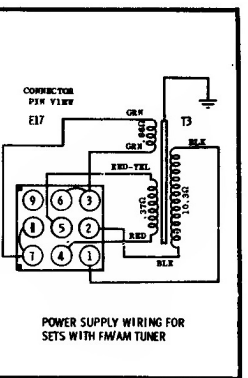
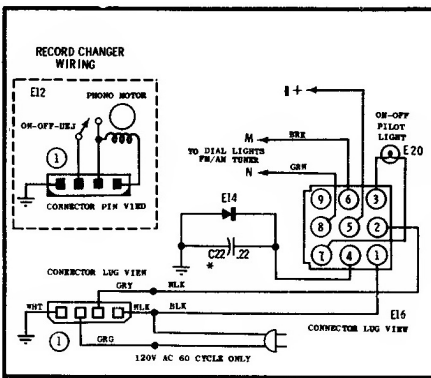
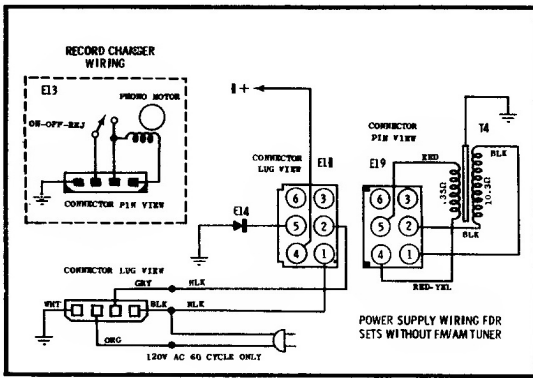
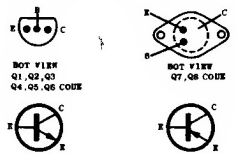

SCHMATIC DIAGRAM - HS-2334

MOTOROLA Chassis HS-2334

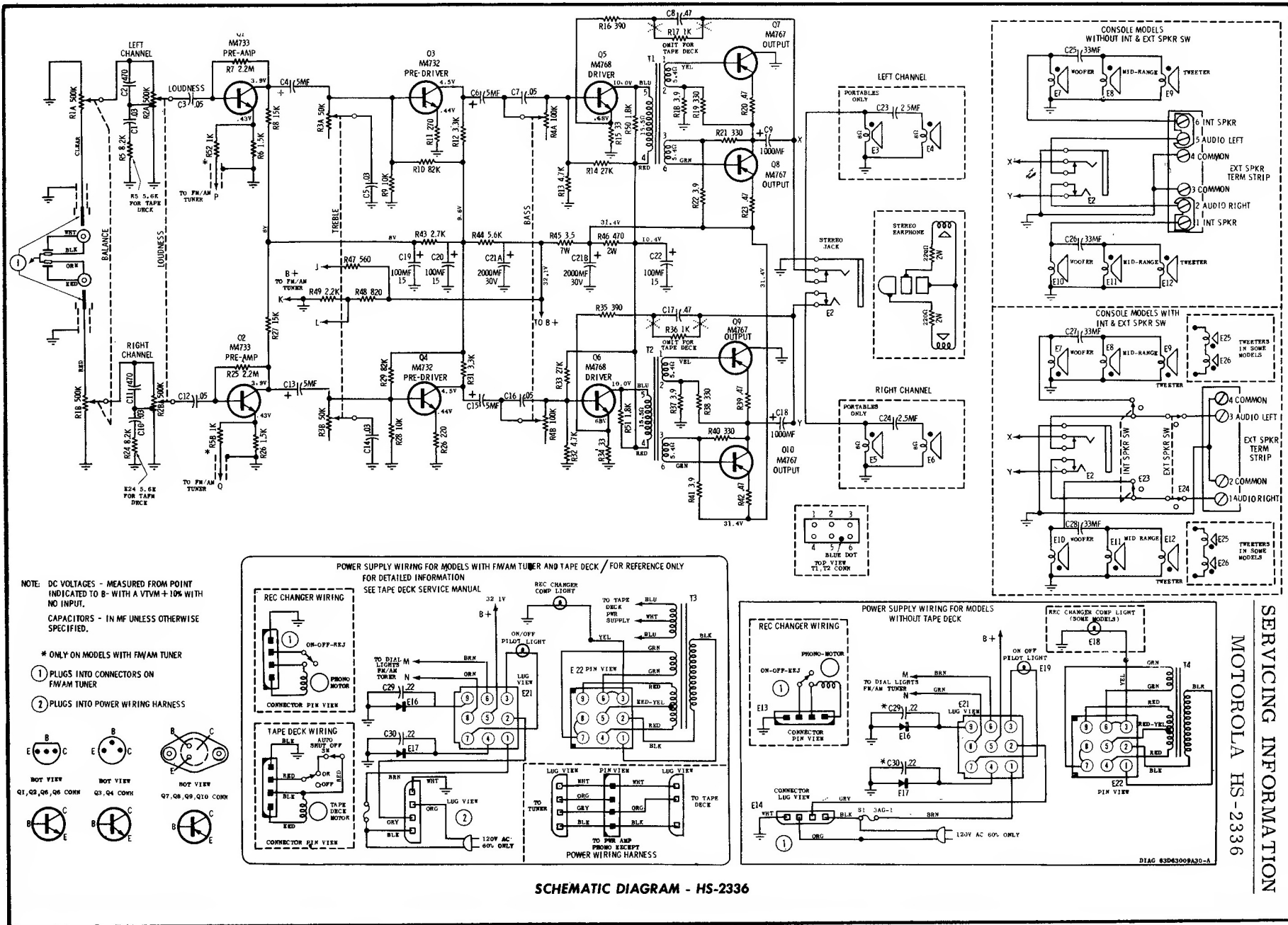

SCHMATIC DIAGRAM - HS-2336